

Fact sheet **ECO-Skate** RN27

ROTO Load moving system, 360 ° rotatable, 3-/4- load points

HTS

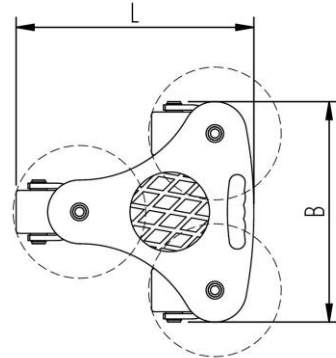
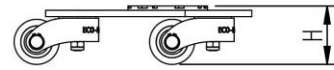

Specification:

Heavy-duty load moving system for the professional indoor heavy load transport on clean, smooth and level floors. Designed as a rotating load moving system with anti slip rubber pads and high-quality HTS 3-component polyurethane wheels, which are abrasion-resistant, cut-resistant and non-marking and suitable for all smooth and level floors with slight unevenness. In combination with an S, DUO or other ROTO chassis with the same installation height it forms a secure overall system with 3 load points. (with secured load also with 4-point support if the operating instructions are observed).

Technical data of load moving system:

# 10 027 01 40	Ø 150 mm	6,0 x 80 = 480 mm ² ▼ 20,8 MPa
MAT NY, 80 Shore D	L x B x H 448 x 415 x 110 mm	14,4 cm ²
2700 daN		75 daN*
# 3	18 kg	60 daN*

Equipped with the following wheel:

# 11 085 10 14	6,0 x 80 = 480 mm ² ▼ 20,8 MPa
MAT NY, 80 Shore D	1000 daN
Ø85x87 - Ø25 mm	V _{max} = 2 km/h



Please always observe the operating instructions, their safety instructions and local conditions!

# Part No.	# Number of wheels	Ø Load Area in mm	Area mm ² of the roller surface pressure ▼ N / mm ²	→ Traction* in daN, required force to move the load at a steady speed of 2 km/h under ideal conditions
MAT Wheel material layer, core: AL Aluminium, NY Nylon PU Polyurethane, ST Steel	Dimensions of wheel, inside ball bearing diameter mm	Dimensions in mm L x B x H	Loaded area per skate in cm ²	
Carrying Capacity of load moving skate in daN at 2km/h max.	Weight kg	Steering bar length D for L, adjustability V for S and DUO skate systems	Starting resistance* in daN, required force to start moving, under ideal conditions	* Varies depending on the tolerances of the floor and ambient situation. All information without guarantee.